

GOOD HOUSEKEEPING PLAN



**Charles County Government
Department of Planning and Growth Management**

**College of Southern Maryland Center for
Transportation Training
5825 Radio Station Road
La Plata, Maryland 20646**

November 2025

TABLE OF CONTENTS

1.0	REGULATORY BACKGROUND & INTRODUCTION	1
1.1	Objectives	1
1.2	Charles County GHP Program Methodology	1
1.3	Property Management Activities	2
1.4	Potential Stormwater Pollutants	2
2.0	RESPONSIBILITIES	4
2.1	GHP Implementation	4
2.2	Plan Review and Modification	4
2.3	Distribution and Recordkeeping	4
2.4	Inspections	4
2.4.1	GHP Site Inspections	5
2.4.2	Conveyance System Inspections	5
2.5	Spill Response	5
2.6	Training	5
3.0	BEST MANAGEMENT PRACTICES (BMPs)	7
3.1	Applicability of BMP Fact Sheets	7
3.2	BMP Fact Sheets	7

List of Tables

TABLE 1-1	RESPONSIBILITIES BY ACTIVITY	2
TABLE 1-2	POTENTIAL STORMWATER POLLUTANTS AND THEIR SOURCES.....	3

List of BMP Fact Sheets

GH-01	-	Waste Management
GH-02	-	Vehicle and Equipment Storage
GH-03	-	Vehicle/Equipment Refueling
GH-04	-	Vehicle Maintenance
GH-05	-	Vehicle/Equipment Washing
GH-06	-	Material Storage
GH-07	-	Aboveground Storage Tanks
GH-08	-	Citizen Drop-Off Centers
GH-09	-	Stockpiles
GH-10	-	Deicing Materials



List of Appendices

- Appendix A: BMP Improvement Memorandum and GHP Applicability Certification
Appendix B: GHP-Applicable Facility Location Map
Appendix C: GHP Site Inspection Checklist
Appendix D1: GHP Stormwater Conveyance Inspection Checklist
Appendix D2: Stormwater Conveyance Inspection Guidance Document
Appendix E: General Spill Response Procedures

List of Acronyms

- AST - Aboveground Storage Tank
BMP - Best Management Practice
CFR - Code of Federal Regulations
GHP - Good Housekeeping Plan
MDE - Maryland Department of the Environment
MS4 - Municipal Separate Storm Sewer System
NPDES - National Pollutant Discharge Elimination System
SPCC - Spill Prevention, Control, and Countermeasure Plan

1.0 REGULATORY BACKGROUND & INTRODUCTION

Polluted stormwater runoff has the potential to enter the Charles County's storm sewer systems (referred to as a municipal separate storm sewer system or MS4), and then discharge, untreated, into local water bodies. To address this potential stormwater pollution, Charles County is required to obtain a NPDES permit from the Maryland Department of the Environment (MDE). The NPDES Permit requires Charles County to take actions to prevent stormwater pollution, maintain storm sewer systems, monitor stormwater discharges, and develop and implement comprehensive management programs to minimize the discharge of pollutants from the storm sewer system.

To comply with Part IV.D.4.b of the County's Phase I MS4 Permit, Charles County must develop, implement, and maintain a Good Housekeeping Plan (GHP) for certain County-owned properties not required to be covered under Maryland's General Permit for Discharges from Stormwater Associated with Industrial Activities (*General Permit 12-SWA / 20-SW*).

To support this effort, a "Good Housekeeping Plan Applicability Certification" has been developed to evaluate and document if a specific County-owned facility is subject to the GHP requirements. The "GHP Applicability Certification" includes the following ten (10) potential stormwater polluting activities. If any of the covered activities are performed at the facility, then that facility is required to implement a site-specific GHP. The GHP will include each of the potential stormwater-polluting activities identified in the "GHP Applicability Certification" and corresponding pollution prevention procedures.

- | | |
|---|---|
| ❖ Waste Management | ❖ Outdoor Material Storage |
| ❖ Outdoor Vehicle and Equipment Storage | ❖ Outdoor Aboveground Storage Tanks (containing hazardous or regulated materials) |
| ❖ Outdoor Vehicle/Equipment Refueling | ❖ Citizen Drop-Off Center |
| ❖ Outdoor Vehicle Maintenance | ❖ Outdoor Stockpiles |
| ❖ Vehicle/Equipment Washing | ❖ Deicing Materials |

1.1 Objectives

The GHP was developed to outline suitable practices, procedures, and protocols, or Best Management Practices ("BMPs") for reducing and/or preventing stormwater pollution associated with operations at covered County-owned properties. The intent of the pollution prevention procedures included in the GHP is to limit the release of materials with the potential to impact stormwater, this includes reducing or eliminating (to the extent practical):

- ❖ The occurrence of spills and leaks;
- ❖ The accidental dumping or release of materials;
- ❖ The accumulation of waste, trash, debris, unused parts/equipment, etc.;
- ❖ The exposure of hazardous materials to precipitation/run-off;
- ❖ Stormwater run-off contamination by improperly stored materials; and/or
- ❖ Illicit discharges to the storm drain system.

1.2 Charles County GHP Program Methodology

Charles County Department of Planning and Growth Management is responsible for the implementation and maintenance of the GHP program.

To develop the GHP, 151 potentially GHP-applicable facilities were identified and asked to complete a self-assessment survey to determine if GHP-applicable activities take place onsite. Based on the survey responses, the list of potentially GHP-applicable facilities was narrowed to 54 facilities. Site visits were conducted at these 54 facilities to confirm their applicability.

The site visits consisted of assessing the facility for GHP-triggering activities via the “*GHP Applicability Certification*” and any improvements which could be made to the facility’s BMPs. The “*BMP Improvement Memorandum and GHP Applicability Certification*” can be found in **Appendix A**.

The site visits and self-assessment surveys determined that 35 Charles County facilities are applicable under the GHP, including the College of Southern Maryland Center for Transportation Training, for which this GHP provides coverage.

The “*GHP-Applicable Facility Location Map*”, depicting all applicable Charles County facilities, can be found in **Appendix B**.

This GHP is to be submitted in the Annual MS4 Permit Report for the third year of the current MS4 permit term (2022-2027) and implemented thereafter.

1.3 Property Management Activities

Charles County Government lessees manage properties throughout the County which provide crucial services and improve the quality of life of County residents. These facilities fulfill needs such as providing recreational opportunities and training. The lessees are responsible for performing the maintenance and operation of these facilities to ensure their continued function.

1.4 Responsibilities

Lessees are responsible for certain activities conducted at County properties. Table 1-1 below describes each covered activity applicable to the College of Southern Maryland Center for Transportation Training and the position title responsible for implementing the best management practices associated with that activity.

TABLE 1-1 RESPONSIBILITIES BY ACTIVITY

Covered Activity	Responsible Party
Outdoor Vehicle and Equipment Storage	Assistant Director of Facilities Management, Operations & Planning
Outdoor Vehicle/Equipment Refueling	Assistant Director of Facilities Management, Operations & Planning
Outdoor Material Storage	Assistant Director of Facilities Management, Operations & Planning

1.5 Potential Stormwater Pollutants

Table 1-2 on the following page provides a list of common potential pollutants that may result from the GHP-regulated activities identified above. Understanding the sources of these pollutants can help in achieving the goals and objectives of the GHP program.

TABLE 1-2 POTENTIAL STORMWATER POLLUTANTS AND THEIR SOURCES

		Waste Management	Vehicle/Equipment Storage	Vehicle/Equipment Refueling	Vehicle Maintenance	Vehicle/Equipment Washing	Material Storage	Aboveground Storage Tanks	Citizen Drop-Off Center	Stockpiles	Deicing Materials
Pollutants	Sources	Associated GHP Activity									
Sediment	Land disturbance; erosion; paved surfaces; material stockpiles; waste storage; salt/abrasive application	X				X	X		X	X	X
Hydrocarbons <i>(petroleum compounds)</i>	Leaking vehicle and equipment; vehicle and equipment cleaning; spills; improper storage; maintenance activities; scrap metal disposal; improper disposal	X	X	X	X	X	X	X	X		
Metals	Vehicle brake and tire wear; vehicle/equipment exhaust; batteries; galvanized metal; paint and wood preservatives; fuels, pesticides, and cleaners; vehicle fueling, maintenance, and washing; industrial waste	X	X	X	X	X	X	X	X		
Toxic Chemicals	Pesticide application; improper chemical storage; leaks and spills from storage containers; leaking vehicles; maintenance activities	X	X		X	X	X	X	X		
Chlorides	De-Icing chemicals										X
Trash/Debris	Improper waste storage and disposal; leaking trash containers; littering; poor housekeeping	X	X				X		X		
<i>Nutrients (nitrogen and Phosphorus)</i>	Fertilizers; malfunctioning septic systems; sewer overflows; animal/pet waste; vehicle washing; decaying grass and leaves; leaking trash containers; atmospheric deposition	X				X	X		X		

2.0 RESPONSIBILITIES

2.1 GHP Implementation

A separate GHP is required for each covered facility. The Assistant Director of Facilities Management, Operations & Planning of the College of Southern Maryland is accountable for the administration and implementation of the GHP at the College of Southern Maryland Center for Transportation Training and has the authority to commit the necessary resources to implement this Plan. The Assistant Director of Facilities Management, Operations & Planning shall ensure that facility personnel involved in any GHP-covered activities identified in this Plan, are provided with access to, and are familiar with, the contents of this Plan.

2.2 Plan Review and Modification

The “*GHP Applicability Certification*” completed for the College of Southern Maryland Center for Transportation Training must be reviewed and updated once every permit term (every five (5) years), or within one (1) year of substantial changes to the facility’s operations that could reasonably contribute to stormwater pollution. Any newly constructed/acquired facility must be assessed within one (1) year of initiating operations at the facility. This facility’s GHP must be amended and reissued to the facility within one (1) year of any changes to the facility’s “*GHP Applicability Certification*”. The “*GHP Applicability Certification*” completed for the College of Southern Maryland Center for Transportation Training can be found in **Appendix A**.

When warranted, the BMP Fact Sheets provided in Section 3.0 may need to be updated or revised. At the same time, additional BMP Facts Sheets may be added. The need for such updates or modifications will be at the discretion of Charles County Department of Planning and Growth Management.

2.3 Distribution and Recordkeeping

This GHP will be maintained by the Charles County Department of Planning and Growth Management and distributed to facility personnel. Copies will be made available electronically on the Charles County website.

All inspection documentation associated with the GHP will be conducted and maintained electronically within the OpenGov Enterprise Asset Management System, formerly known as the Cartegraph Asset Management System. Training documentation will be maintained electronically.

2.4 Inspections

The GHP requirements in Charles County’s MS4 permit mandates that the College of Southern Maryland Center for Transportation Training has the following:

1. Written procedures for annually assessing the property to prevent the discharge of pollutants, spills, and leaks into the Charles County’s storm sewer system; and
2. Written procedure for performing stormwater conveyance system inspections and for removing debris that may cause clogging, backups, and flooding.

To meet these requirements, the Charles County Government will be required to complete routine site inspections and stormwater conveyance system inspections as detailed below. Facility management will be responsible for ensuring the necessary inspections are completed within the required timeframes, that corrective actions (if needed) are performed, and that records of inspections and completed corrective actions are maintained for at least five (5) years. The routine site inspections and stormwater conveyance

system inspections are conducted and maintained within the OpenGov Enterprise Asset Management System.

2.4.1 GHP Site Inspections

The GHP Site Inspection will be performed to ensure that the College of Southern Maryland Center for Transportation Training is being properly maintained and that there are no visible signs of pollutants entering the stormwater system. An example of the “*GHP Site Inspection Checklist*”, conducted and maintained in the OpenGov Enterprise Asset Management System, is provided in **Appendix C**. At a minimum, the facility is to be inspected once a year.

2.4.2 Conveyance System Inspections

Stormwater conveyance systems are generally comprised of curbs and gutters, catch basins, inlet structures, swales, channels, piping, culverts, detention ponds, outfalls, or other structures that are used to collect, contain, and convey stormwater runoff.

The unimpeded movement of stormwater through conveyance systems is critical in avoiding backups and flooding, which can impede facility operations and damage property. Routine inspections and preventative care of stormwater conveyance systems can ensure these systems function as intended and prevent the need for costly and time-consuming repairs and retrofits.

The Charles County Government is required to conduct routine stormwater conveyance system inspections to ensure the free flow of stormwater within the conveyance systems. An example of the “*GHP Stormwater Conveyance System Inspection Checklist*”, conducted and maintained in the OpenGov Enterprise Asset Management System, is provided in **Appendix D1**. For additional guidance on completing stormwater conveyance system inspections, the “*Stormwater Conveyance Inspection Guidance Document*” is provided in **Appendix D2**. At a minimum, the conveyance system inspections are to be conducted once a year.

2.5 Spill Response

This GHP aims to reduce the potential for spills or leaks to occur; however, procedures must be in place to address those events should they take place. A discharge of oil or other chemicals to groundwater, surface water, or soil is prohibited by regulation, and immediate action must be taken to control, contain, and recover discharged products. Please note that spill containment and cleanup are of secondary importance when compared to the health and safety of personnel. The immediate action(s) to be taken will depend on the capabilities of the person discovering the incident, his or her training and understanding of the incident, and the resources available in the area of the incident. In all cases, the initial response actions should only be conducted in a safe manner, placing the safety and security of people in the area above all other factors.

The “*General Spill Response Procedures*”, which outlines procedures for stopping, containing, and cleaning up spills as well as notification requirements, is located in **Appendix E**.

2.6 Training

As part of the GHP requirements within the Charles County’s Phase I NPDES permit, annual training must be provided to all appropriate staff and contractors. Such training shall be provided to any individuals responsible for implementing the GHP, performing the required inspections, or involved in any of the GHP-covered activities identified in this GHP. The required training shall focus on the duties and responsibilities

assigned to site personnel in implementing the GHP and the BMPs prescribed in this GHP for preventing, reducing, and eliminating the discharge of pollutants during facility activities.

The Charles County's Department of Planning and Growth Management will be responsible for developing the required training and disseminating it to GHP-covered facilities. The College of Southern Maryland Center for Transportation Training will be responsible for identifying staff/contractors who must attend annual training, ensuring identified staff complete the required training, and maintaining records that document training dates and attendees. Training records and other documentation shall be maintained electronically.

3.0 BEST MANAGEMENT PRACTICES (BMPs)

This section contains a BMP Fact Sheet for each of the ten (10) GHP-regulated activities. Charles County's operations are not limited to the BMPs contained within this document; nor is Charles County required to implement all of the pollution prevention measures identified within each BMP Fact Sheet. Charles County should select and implement those measures that are applicable and have the greatest potential for reducing stormwater pollution.

The BMP Fact Sheets contained within this document offer recommended protocols for a particular activity. These pollution prevention measures are considered non-structural BMPs with a focus on source control of potential pollutants.

3.1 Applicability of BMP Fact Sheets

The "*GHP Applicability Certification*" completed for the College of Southern Maryland Center for Transportation Training has identified the activities conducted at this facility that require coverage under this GHP. Each of the BMP Fact Sheets shall be marked as to whether they are applicable or not applicable to the College of Southern Maryland Center for Transportation Training. The Applicable/Not Applicable indicator on each BMP Fact Sheet can be revised in response to changes in operations at the facility.

3.2 BMP Fact Sheets

BMP Fact Sheets can be found on the following pages. For the sake of consistency, the general outline of a BMP Fact Sheet will be as follows:

- ❖ Identification of GHP-covered activity.
- ❖ Applicability of the BMP Fact Sheet to the facility.
- ❖ A general description of the concern the activity poses to stormwater.
- ❖ Recommended pollution prevention measures for reducing/eliminating stormwater pollution.
- ❖ Additional sources of information, if applicable.

WASTE MANAGEMENT

GH-01Not Applicable Applicable **CONCERN**

Improperly managed waste can allow trash and debris to be washed into storm drains which poses a concern to water quality, marine life, and public health. It also has the potential to create obstructions in the drainage system, which can lead to backups and flooding. Additionally, improper storage and handling of waste materials can allow pollutants including oils and greases, toxic and chemical compounds (including nutrients), bacteria, metals, and other potentially hazardous wastes to enter waterways.

POLLUTION PREVENTION MEASURES**General (applicable to all waste management activities)**

- 1) Provide suitable containers, preferably with working covers, to collect waste materials.
- 2) Ensure that appropriate waste containers are available in areas where waste is generated.
- 3) Provide cover over waste storage areas, if feasible.
- 4) Avoid positioning waste receptacles near storm drains, water bodies, or areas of concentrated runoff.
- 5) Ensure that lids to waste containers (*if present*) are kept closed to prevent the intrusion of precipitation and prevent trash from blowing out of the receptacle.
- 6) For waste receptacles, which do not have lids and could leak, containers should be inspected regularly and controls (e.g., containment, spill response, etc.) shall be enacted whenever leaks or dry-weather discharges are observed.
- 7) Routinely inspect waste containers, roll-offs, compactors, and other waste receptacles for the presence of excessive waste accumulation and overflowing containers.
- 8) Ensure that wastes accumulating on the ground are placed in a suitable waste container.
- 9) Ensure that wastes are removed from the facility regularly by a licensed and contracted vendor.
- 10) Repair or replace damaged waste container lids.

Trash Compactors

- 1) Routinely inspect trash compactors for malfunctioning equipment or leaking hydraulic oil and provide the appropriate spill response if leaking equipment is encountered.
- 2) Regularly inspect compactors for leaking fluids and implement appropriate controls such as spill response/cleanup, collection or diversion of released fluids, providing secondary containment, etc. whenever leaks or dry-weather discharges are observed.

Scrap Metal Collection Containers

- 1) Avoid placing oily or grease-covered items in uncovered scrap metal recycling collection containers. If needed, wrap oily/greasy items in plastic garbage bags before placing them in the collection container.

Hazardous/Universal Wastes

- 1) Ensure that hazardous waste and universal wastes (e.g., batteries, bulbs, etc.) are collected and stored indoors or within covered collection containers.
- 2) Verify that hazardous/universal waste collection containers are in good condition, not leaking, and compatible with the wastes being stored.

WASTE MANAGEMENT

Street Sweeping / Vector Truck Material Storage

- 1) Do not site storage areas near storm drains, open water bodies, or areas of concentrated runoff.
- 2) Install sediment control devices (e.g. silt fence, silt socks, hay bales, etc.) around the staging area. Inspect these controls regularly and replace them as needed.
- 3) Cover the materials staging area, if feasible.
- 4) Provide oil-absorbent booms if necessary to control oily discharge. Inspect and replace booms regularly.
- 5) The staging area should be checked periodically for evidence of sediment migrating outside of the staging area. Material that has migrated out of the staging area should be promptly swept and returned to the staging area or disposed of.

Waste Cooking Oil/Grease

- 1) Maintain storage containers indoors or within a covered location, if feasible.
- 2) Storage containers shall be secured to prevent infiltration of precipitation and accidental/intentional spills or releases.
- 3) Carefully transfer waste oil/grease to the appropriate collection container to avoid spills.
- 4) Maintain suitable spill response equipment near collection containers. Immediately clean up any spilled oil/grease. Keep the exterior of the collection container clean and free of spilled oil/grease.
- 5) Provide secondary containment for collection containers, if feasible.

VEHICLE AND EQUIPMENT STORAGE

GH-02Not Applicable Applicable **CONCERN**

Vehicles and equipment may be stored onsite to support various Charles County operations (e.g., construction, maintenance, snow removal, roadside assistance, mass transit, mowing, etc.). Examples of Charles County owned and operated vehicles and equipment stored onsite at any given time include but are not limited to, the following: cars, trucks, buses, emergency response vehicles, garbage trucks, heavy equipment (backhoes, frontend loaders, etc.), forklifts, towable generators, portable light stands, and roadside equipment. Vehicle and equipment storage is considered a pollutant source due to the potential for incidental releases of petroleum products, lubricants, and various automotive fluids.

POLLUTION PREVENTION MEASURES

- 1) When possible/practical, store vehicles and equipment inside or under cover to prevent exposure to precipitation.
- 2) If vehicles or equipment must be stored outside, store vehicles/equipment in designated areas away from areas of concentrated runoff, storm drains, and other stormwater conveyances.
- 3) Vehicles and equipment shall be staged on impervious (asphalt or concrete) surfaces;
- 4) Keep truck beds clean and ensure potential stormwater pollutants are stored in closed containers, covered, or otherwise protected from stormwater exposure.
- 5) Conduct routine visual inspections of vehicles and equipment for the presence of leaks and respond accordingly.
- 6) Leaking vehicles/equipment should be moved inside or under cover. At a minimum, drip pans or absorbent pads shall be used to contain the leak until the vehicle/equipment can be relocated and the leak addressed.
- 7) Drain all fluids from wrecked or heavily damaged vehicles and equipment before storage.
- 8) Have an adequate supply of appropriate spill response equipment readily available and clean up all spills and leaks immediately utilizing dry cleaning techniques (e.g. absorbents and brooms).
- 9) Train staff in spill response so that incidents are addressed in a timely fashion.
- 10) Do not wash down areas where leaks have collected on ground surfaces; use dry cleaning methods such as granular absorbents and brooms.

VEHICLE AND EQUIPMENT REFUELING

GH-03Not Applicable Applicable **CONCERN**

Refueling activities associated with Charles County vehicles and equipment can result in a discharge of fuel (gasoline and diesel fuel), which has the potential to enter the storm drain system and/or a nearby waterway. Such releases can introduce hydrocarbons, metals, and other toxic chemicals to stormwater runoff.

POLLUTION PREVENTION MEASURES**General Procedures (applicable to all refueling activities)**

- 1) Routinely (*at least daily*) inspect the fuel dispensing area for any spills or leaks.
- 2) Routinely inspect fuel-dispensing equipment looking for leaking or damaged equipment. Damaged or malfunctioning equipment shall be taken out of service until it has been repaired.
- 3) Fuels will only be dispensed into authorized vehicles, equipment, and approved containers.
- 4) Vehicle operators must always remain outside of their vehicles and in attendance of fuel dispensers while dispensing fuel.
- 5) Third-party contractors must be trained in proper refueling procedures and pollution prevention.
- 6) Do not utilize a foreign object to keep the dispenser nozzle in the open position. If present, a "hold-open" latch on the nozzle may be used.
- 7) Do not "top off" a vehicle's fuel tank once the dispenser nozzle's automatic shut-off has been activated. Topping off tanks may result in spills. Post signs in fueling areas warning vehicle operators against "topping off" of vehicle fuel tanks.
- 8) After refueling has stopped, allow several seconds to pass before removing the nozzle and returning it to the dispenser. This will prevent incidental dripping from the nozzle.
- 9) Employees refueling vehicles shall note the location of the "Emergency Fuel Shut Off" switch, to be used to stop the flow of fuel to the dispensers in the event of a release or emergency.
- 10) Have an adequate supply of appropriate spill response equipment readily available and clean up all spills immediately utilizing dry cleaning techniques (e.g. absorbents and brooms).
- 11) Immediately clean up and dispose of used absorbent material.
- 12) Do not wash down fueling areas; use dry cleaning methods such as granular absorbents and brooms.
- 13) Conduct refueling activities over impervious (e.g. concrete) surfaces. Place drip pans or absorbent pads under the nozzle if fueling occurs over a permeable surface such as grass or soil.
- 14) Install oil control devices in storm drains that may receive contaminated runoff from fueling areas.
- 15) Cover fueling areas with a canopy or roof to prevent direct contact with rainfall. Direct run-on away from fueling areas and collect fueling area run-off in a dead-end sump or oil-water separator.

Mobile Equipment Refueling

- 1) Refuel equipment on an impervious surface, downgradient of, and at the farthest practical distance from any storm drain, stormwater conveyance, stormwater management feature, or waterway.
- 2) Utilize secondary containment when refueling equipment (when practical).
- 3) Ensure mobile refuelers are parked in designated locations and away from areas of concentrated run-off, storm drains, and other stormwater conveyances.
- 4) Ensure that procedures are in place and that staff is properly trained in spill response/cleanup so that leaks and spills are addressed appropriately and promptly.

VEHICLE MAINTENANCE

GH-04Not Applicable Applicable **CONCERN**

Vehicle and equipment maintenance can impact the water quality of nearby waterways by exposing stormwater to various pollutants including petroleum hydrocarbons, solvents, antifreeze/coolants, used oil, lubricating oil, grease, brake fluid, metals, and various chemicals. Additionally, vehicles that are wrecked or awaiting repair can be a source of pollution if leaking fluids are not properly controlled.

POLLUTION PREVENTION MEASURES

- 1) Conduct vehicle and equipment maintenance activities indoors.
- 2) Make sure incoming vehicles and equipment are inspected for leaking fluids and oil.
- 3) Move leaking vehicles or equipment indoors or under cover as soon as possible. At a minimum, a drip pan or absorbent pads shall be utilized to contain the leak until the vehicle/equipment can be relocated and the leak addressed.
- 4) Avoid performing maintenance on vehicles in close proximity to exterior doorways, which may allow released fluids to migrate outdoors.
- 5) Have an adequate supply of appropriate spill response equipment readily available and clean up all spills and leaks immediately utilizing dry cleaning techniques (e.g. absorbents and brooms).
- 6) Keep maintenance areas neat and well organized. Remove dirt, debris, and used absorbent regularly.
- 7) Inspect maintenance areas as well as maintenance equipment on a routine basis.
- 8) Store vehicles, parts, and generated wastes indoors or off the ground and under cover whenever possible. When practical, provide secondary containment.
- 9) Promptly transfer used fluids to the proper waste container; do not leave full drip pans or other open containers around the shop. Empty and clean drip pans and containers regularly.
- 10) Waste liquids shall not be poured into floor drains, sinks, outdoor storm drain inlets, or other storm drains or sewer connections. Liquid wastes are to be collected in properly labeled containers and disposed of by a licensed waste hauler or other appropriate method.
- 11) Store leaking batteries in a sealed container and provide secondary containment, if feasible.
- 12) Clean all parts indoors utilizing a self-contained parts washer.
- 13) Do not hose down indoor service areas to storm drains or areas where it can seep into groundwater.
- 14) Maintain floor drains in good working order and inspect for proper function on a routine basis. Consider plugging floor drains that discharge to the storm sewer.
- 15) Ensure oil/water separators (if present) are maintained in proper working order and are checked on a routine basis for the presence of oil.
- 16) If maintenance work must be performed outdoors, adhere to the following requirements:
 - Conduct maintenance activities over an impervious surface, away from stormwater inlets.
 - Cover outdoor maintenance areas and direct stormwater run-on away from the area.
 - Use drip pans or drop cloths underneath the equipment to catch leaks and drips.
 - Have an adequate supply of appropriate spill response equipment readily available.
 - Clean all spills immediately using dry cleaning techniques (e.g. absorbents and brooms).
 - Avoid performing maintenance activities during precipitation events.
 - Limit temporary outdoor maintenance activities to a single shift/day if additional time is needed to cover the work area at the end of each day/shift.

VEHICLE AND EQUIPMENT WASHING

GH-05Not Applicable Applicable **CONCERN**

Vehicle and equipment washing can generate washwater that contains oil, grease, organic compounds, surfactants, phosphates, metals, and suspended solids. If vehicles/equipment are washed outdoors on impervious surfaces, dirty washwater can contaminate stormwater that ends up in waterways. Washing equipment over pervious surfaces can allow washwater to seep into the ground contaminating groundwater.

POLLUTION PREVENTION MEASURES

- 1) Vehicle and equipment washing should only be conducted in designated indoor wash bays that capture and recycle washwater to the extent practical.
- 2) Wastewater from the washing facility should be discharged to the sanitary sewer system under the authorization of a wastewater discharge permit issued by the local municipal authority.
- 3) The floor of indoor vehicle wash bays should be completely bermed or sloped to collect wash water and prevent migration outdoors.
- 4) No other activities (e.g., fluid changes, repairs, material storage) shall be performed in wash areas.
- 5) Keep the wash bay neat and well organized. Sweep or pick up all trash and debris daily or as needed.
- 6) Solid materials accumulated on vehicles or in vehicle beds (e.g. salt, soil, grass, etc.) shall be knocked off or otherwise removed from the vehicle (while inside the wash bay) prior to washing. Solid materials shall be collected and disposed of properly.
- 7) For vehicles too large to completely fit in the wash bays, only the portion of the vehicle physically located in the confines of the wash bay shall be cleaned. The vehicle shall then be rotated to allow for the remaining portion of the vehicle to be washed.
- 8) Use nozzles that automatically turn off water when not in use and consider high-pressure, low-volume sprays.
- 9) Avoid detergents as much as possible. If detergents are necessary, use a biodegradable, phosphate-free detergent.
- 10) If discharging to an oil-water separator, use a non-emulsifying detergent.
- 11) Inspect floor drain systems, holding tanks, and conveyances associated with designated wash areas regularly. Maintain oil/water separators and/or process flowthrough separators on a routine basis.
- 12) Use commercial car washes when vehicle or equipment washing cannot be performed onsite without causing impacts to stormwater.
- 13) If washing must occur onsite and outdoors, use a designated impervious area that is marked with posted signs indicating proper washing procedures. This area must be bermed to contain the wash water and graded to direct the wash water to the sanitary sewer, an oil-water separator, a holding tank, a dead-end sump, or other containment area. Captured water shall be disposed of properly.
- 14) Avoid steam cleaning and engine/undercarriage washing which can produce high pollutant concentrations. If steam cleaning or engine washing is necessary, perform such cleanings within isolated indoor areas, and ensure wash water is treated and discharged to the sanitary sewer (if permitted to do so) or captured for off-site disposal.
- 15) Train staff in proper washing techniques and how to confine washing to designated wash areas.
- 16) Consider alternatives to washing such as using air to blow grass and debris from small equipment, wet-wiping equipment with rags, etc.

MATERIAL STORAGE

GH-06Not Applicable Applicable **CONCERN**

The storage of petroleum products, chemicals, paints, cleaners, pesticides, fertilizers, bags of erodible materials like sand, cement, and soil, and other potential pollutants can negatively impact surface waters through the accidental releases or leaching of materials into stormwater. Unprotected outdoor storage areas can generate a wide range of stormwater pollutants, such as sediment, nutrients, toxic materials, and petroleum products.

POLLUTION PREVENTION MEASURES

- 1) Whenever possible, store containers (e.g. drums, bins, bags, cans, and totes) indoors or under cover to limit exposure to stormwater.
- 2) Designate specific areas for material delivery and storage that are away from heavy traffic areas, storm drains, stormwater conveyances, and areas of concentrated run-off.
- 3) Designated outdoor storage areas should be paved or consist of an impervious surface.
- 4) Provide secondary containment for materials whenever possible or required per 40 CFR Part 112.
- 5) Store materials on pallets to prevent stormwater run-on from coming into contact with materials, prevent container corrosion, and allow for better leak detection. Pallets must be in good condition and promptly replaced once damaged or deteriorated.
- 6) Stack containers according to the manufacturer's recommendations to avoid damage.
- 7) Immediately replace damaged, corroded, or leaking containers.
- 8) Ensure all storage containers are clearly labeled with their contents.
- 9) Keep containers tightly sealed after use.
- 10) Maintain an accurate inventory of hazardous substances and limit on-site storage to that which is necessary to support facility operations.
- 11) Keep storage areas neat and well organized; remove debris and unneeded material promptly.
- 12) If empty drums are stored outdoors, ensure that all openings are equipped with caps to prevent water intrusion and that the drum/storage area is labeled "Empty Drums".
- 13) Have an adequate supply of appropriate spill response equipment readily available and clean up all spills and releases immediately utilizing dry cleaning techniques (e.g. sweeping/absorbents).
- 14) Clean up all migrating dry materials upon discovery and address the source of the release.
- 15) Provide perimeter controls (e.g., berms, rock check dams, etc.) for erodible stockpiles of materials such as mulch, sand, and gravel to prevent migration into the stormwater system.
- 16) Routinely inspect material storage areas for leaks, material migration, and damaged or corroded containers. Ensure that secondary containment and other perimeter controls are in satisfactory condition.
- 17) Additional visual inspections of outdoor storage areas should be conducted after significant rainfall events (i.e., greater than 0.5 inches).

ABOVEGROUND STORAGE TANKS

GH-07Not Applicable Applicable **CONCERN**

Aboveground storage tanks (ASTs) may be used to store fuels, automotive fluids, chemicals, or deicing fluids. Only ASTs containing hazardous or regulated materials are considered in this BMP. Leaks from tanks, piping, or other equipment and releases during fluid transfers can all impact stormwater quality. It is critical to maintain ASTs in good working condition to prevent spills and/or releases from occurring. Improperly managed storage tanks can cause significant environmental impacts.

POLLUTION PREVENTION MEASURES**General (applicable to all storage tanks)**

- 1) ASTs should be installed and maintained in accordance with [COMAR 26.10](#) and applicable fire codes.
- 2) ASTs should be provided with secondary containment, whenever feasible or required by regulation.
- 3) Secondary containment areas shall be maintained clean and dry; drain valves must be kept closed; accumulated liquid shall only be discharged if there are no visible signs of impacts, and in accordance with applicable regulations.
- 4) Inspect ASTs monthly to identify any leaking or malfunctioning equipment and ensure tanks are functioning as designed.
- 5) ASTs shall be equipped with a form of liquid-level detection (i.e. sight gauge, electronic monitoring).
- 6) ASTs shall be equipped with overfill prevention (i.e. overfill alarm and/or overfill prevention valve).
- 7) Tanks and piping should be protected from vehicle impact via barriers, bollards, guard rails, etc.
- 8) Install ASTs on solid foundations over impervious surfaces, and away from areas of concentrated runoff, storm drains, and other stormwater conveyances.
- 9) Properly label all storage tanks (e.g., contents, capacity, etc.).
- 10) Keep remote fills and fill port spill buckets clean and dry.
- 11) Keep fill ports, gates, and tank areas secured when not in use to prevent fuel theft and tampering.
- 12) Have an adequate supply of appropriate spill response equipment readily available and clean up all spills and leaks immediately utilizing dry cleaning techniques (e.g. absorbents and brooms).
- 13) Facilities that maintain 1,320 gallons or more of aboveground oil products shall prepare and implement a Spill Prevention, Control, and Countermeasure (SPCC) Plan, per [40 CFR 112](#).
- 14) Facilities that maintain 1,000 gallons or more of used oil or 10,000 gallons or more of virgin oil in ASTs shall obtain an Individual Oil Operations Permit from the MDE, per [COMAR 26.10.01.09](#).
- 15) Owners/Operators of facilities that maintain more than 2,500 gallons of oil in ASTs are required to register each AST with MDE, per [COMAR 26.10.01.10](#).

Bulk Fluid Transfers (Deliveries)

- 1) All bulk fluid transfer operations shall be performed under the direct supervision of knowledgeable Charles County personnel. At no time shall the delivery vehicle or delivery vehicle operator be unsupervised.
- 2) The product level within the tank must be measured and available capacity verified before delivery.
- 3) Deliveries shall be made via fill ports equipped with catch basins to capture drips and spills.
- 4) Ensure an adequate supply of appropriate spill response equipment is readily available.

ABOVEGROUND STORAGE TANKS

- 5) Post signs in delivery area displaying proper delivery procedures and emergency contact information.

Used Oil Tanks

- 1) Charles County personnel must verify the level of product in used oil tanks prior to filling.
- 2) Used oil tanks should only be filled via designated fill ports. Pumping used oil into the tank via a closed piping system is preferred to manually pouring used oil into the tank.

Brine Tanks

- 1) If multiple tanks are located onsite, the tanks should be plumbed to ensure that the complete failure of one tank will not drain all the tanks in the system (tanks must be isolated).
- 2) Minimize seeping and leaking at fittings by properly supporting piping and fittings, using flexible connectors or hoses to reduce stress, and installing corrosion-resistant fittings.
- 3) Consider placing hoses in non-permeable trenches or using drip-less nozzles to reduce repeated small spills.

CITIZEN DROP-OFF CENTER

GH-08Not Applicable Applicable **CONCERN**

Citizen Drop-Off Centers are publicly accessible facilities where residents can drop off used automotive fluids (i.e. oil or antifreeze), municipal waste, recyclable, and/or organic waste, typically free of charge. Improper transfer or management of the waste materials can allow a number of pollutants including oils and greases, toxic and chemical compounds, nutrients, metals, and other wastes to enter waterways.

POLLUTION PREVENTION MEASURES**General (applicable to all materials collected)**

- 1) Clearly identify waste materials accepted by the facility, and clearly mark designated collection areas.
- 2) Waste material should be inspected by a Charles County representative, prior to disposal.
- 3) Avoid positioning waste receptacles near storm drains, water bodies, or areas of concentrated runoff.
- 4) When practical, receiving areas should be covered.
- 5) Do not allow containers to overflow or waste materials to accumulate on the ground.

Automotive Fluid Collection

- 1) Used oil, antifreeze, and automotive fluid receiving areas should be on impervious surfaces, covered, and provided with secondary containment, which shall be maintained clean and dry.
- 2) Provide lidded waste receptacles in the receiving area for the public to dispose of empty containers. Waste receptacles shall be emptied routinely and waste disposed of properly.
- 3) Collection areas shall be inspected daily and all trash and spilled liquids appropriately cleaned up.
- 4) The available capacity of waste liquid collection containers shall be routinely verified and waste removals scheduled, as needed.
- 5) Install appropriate controls to prohibit the overfilling of waste fluid collection containers.
- 6) Place appropriate spill response equipment in close proximity to drop-off areas.
- 7) If aboveground tanks are used to collect waste fluids, refer to BMP Fact Sheet GHP-07 (Aboveground Storage Tanks) for additional recommendations.

Organic Debris Collection

- 1) Routinely transfer collected organic debris/waste to a composting or disposal facility.
- 2) Do not permit composting of organic waste except at properly designed and permitted facilities.
- 3) Enact controls to prevent leaves and other windblown debris from entering stormwater inlets.

Municipal Waste / Recyclables Collection

- 1) Refer to BMP Fact Sheet GHP-01 (Waste Management) for additional recommendations.

STOCKPILES

Not Applicable Applicable

CONCERN

Charles County may stockpile various erodible materials, the type of material can vary depending on the needs of the County. Stockpiled material may include soil, sand, millings, slag, cinders, sawdust, landscaping bark, compost, etc. Exposed stockpiles can easily erode due to wind or precipitation and contribute suspended solids to stormwater runoff.

POLLUTION PREVENTION MEASURES

- 1) Maintain stockpiles of erodible materials within roofed storage buildings or covered storage bins, if feasible. If not, stockpile material on an impervious surface and cover the stockpile.
- 2) Temporary stockpiles should be placed on an impermeable membrane (tarp) for quick clean-up.
- 3) Locate stockpiles away from drain inlets, catch basins, swales, areas of concentrated stormwater flow, water bodies, and environmentally sensitive areas.
- 4) Divert stormwater flows away from/around the stockpiles using a diversion device (e.g., temporary swale, berm, sandbags, or diversion fence).
- 5) Cover temporary stockpiles of erodible materials with a tarp that has been adequately secured. The covers must be in place at all times when the stockpile is not in active use.
- 6) When accessing a portion of the stockpile, only remove a section of the cover to minimize exposure to the elements.
- 7) Use barriers to isolate stockpiled materials from high-traffic areas to prevent tracking of materials.
- 8) Sweep (do not wash or hose down) in front of material stockpile storage areas at regular intervals, following loading and unloading activities, and during times of heavy use.
- 9) If material is observed migrating from the stockpile, clean up all migrated material upon discovery and provide additional controls to reduce migration from the stockpile. If such measures are ineffective implement controls to capture pollutants before they migrate off-site (e.g. silt fencing, inlet filters, filter socks, at-grade inlet protection, etc.).
- 10) Minimize material stockpile inventory based on historical inventory/usage records and public safety operational needs.
- 11) Cold mix asphalt shall be stored on and covered with plastic sheeting or comparable material.
- 12) Routinely inspect outdoor material stockpiles to verify existing controls are functioning properly and for signs of erosion or material transport.

DEICING MATERIALS

GH-10Not Applicable Applicable **CONCERN**

When salt and other de-icing materials are stored outside and uncovered, they have a much higher risk of being eroded and transported offsite by stormwater. Improper de-icing material and sand storage may result in stormwater runoff containing elevated concentrations of sodium chloride and dissolved solids. Sodium chloride (e.g., road salt) is an effective deicer but can be highly corrosive to stormwater facilities. Smaller waterways are at a higher risk to increases in salinity, which can threaten aquatic species. Additionally, runoff containing sodium chloride has the potential to reach drinking water sources where small traces can adversely impact public health.

POLLUTION PREVENTION MEASURES

- 1) Bagged de-icing chemicals must be stored indoors. If stored outdoors bags must be kept on pallets (off the ground) and covered at all times. Bags must be intact without holes or openings.
- 2) Bulk de-icing materials shall be stored under cover and on an impervious surface.
- 3) Bulk salt storage areas/buildings shall not be overfilled so that salt spills out beyond the entrance of the storage area/building.
- 4) Bulk salt storage areas/buildings shall be maintained in a structurally sound condition and in a way that prevents the release of salt and the infiltration of stormwater. Deicing materials should not touch the sides of metal storage containers.
- 5) Barriers such as berms, gates, knee walls, tarps, and/or straw bales shall be placed at the entrances of bulk salt storage areas/buildings to prohibit the migration of salt and prevent contact with precipitation/stormwater runoff.
- 6) Routinely inspect storage areas for migrating materials or deterioration of containment structures. Sweep up all migrating materials upon discovery and repair the source of the migrating pollutant.
- 7) Loading areas should be constructed of impervious material and covered or enclosed, to the extent practical, to reduce potential contact with stormwater.
- 8) Minimize the distance de-icing materials are transported during loading/unloading activities.
- 9) Prevent and/or minimize the spillage of salt and de-icing materials during loading/unloading activities, immediately clean spilled or tracked materials.
- 10) Sweeping of storage and loading/unloading areas shall be conducted immediately following loading/unloading activities.
- 11) Do not store de-icing materials (bulk or bagged) over or immediately adjacent to drains or waterways.
- 12) Control site drainage by diverting stormwater run-on away from storage/loading areas using appropriate measures (e.g., curbing, berms, etc.).
- 13) Slope storage/loading areas to direct salt-contaminated runoff to an appropriate collection area, and in a manner that prevents the runoff from reaching adjacent soil or surface waters.
- 14) Excess salt shall be removed from salt handling equipment (trucks, spreaders, etc.) following use/prior to storage. All cleaning shall occur on an impervious surface, which is sloped or curbed to contain any washwater and direct it to a collection area for recycling or proper disposal.

Appendix A

BMP Improvement Memorandum and GHP Applicability Certification

4 September 2025

MEMORANDUM

TO: Karen Wiggen, Charles County Department of Planning and Growth Management

FROM: Payal Garg, Hannah Piatak, EA Engineering, Science, and Technology, Inc., PBC

SUBJECT: Best Management Practice Improvement Memorandum – College of Southern Maryland Center for Transportation Training

Per Charles County’s current Municipal Separate Storm Sewer System (MS4) permit (Permit Number 22-DP-3322, MD0068365), “The County shall develop, implement, and maintain a good housekeeping plan (GHP) for County-owned properties not required to be covered under Maryland’s Stormwater Industrial General Permit where the activities listed in PART IV.D.4.a (maintenance or storage of vehicles or equipment, storage of fertilizers, pesticides, landscaping materials, hazardous materials, or other materials that could pollute stormwater runoff) are performed.” The GHP will be developed based on the conditions and operations observed at the facilities during the site visits conducted by EA Engineering, Science, and Technology, Inc., PBC (EA) personnel. This Best Management Practice (BMP) Improvement Memorandum summarizes the site visit at the College of Southern Maryland Center for Transportation Training, which serves as the basis for the GHP.

Facility name:	College of Southern Maryland Center for Transportation Training
Facility address:	5825 Radio Station Road, La Plata, MD 20646
Facility points of contact:	Laura Dyson, Assistant Director, Facilities Management
Description of facility activities:	Driver training, vehicle storage and refueling

The EA inspection team, consisting of Tanner Motsko, Callie Paff, and Allison Brown conducted a detailed site walk at the facility on June 22, 2025, from 2:30pm – 3pm. The inspectors were escorted by Mrs. Laura Dyson, who was familiar with the facility’s operations.

During the site visit, EA inspectors observed facility conditions and interviewed facility personnel to complete the GHP Applicability Certification (GHPAC). The purpose of the GHPAC is to determine if the facility requires coverage under the GHP. Based on activities and operations observed during the site visit, EA inspectors determined that the facility is required to be covered under the GHP. The finalized GHPAC Questionnaire can be found in Attachment A.

BMP improvements are recommendations to ensure Charles County’s compliance with Part III.1 of the MS4 permit, which states that County’s shall “Effectively prohibit pollutants in stormwater discharges or other unauthorized discharges into, through, or from the MS4 as necessary to comply with Maryland’s receiving water quality standards.” Table 1 captures the one BMP improvement EA personnel identified for the College of Southern Maryland Center for Transportation Training. Photographs to support the recommended BMP improvements in this memorandum can be found in Attachment B.



Table 1. Recommended BMP Improvements

Recommended BMP Improvement	Priority (Low, Medium, High)	Photograph Reference ID(s)
Waste Management		
Waste management activities are not conducted at this facility.		
Vehicle and Equipment Storage		
EA has no BMP improvements for the facility under this activity.		
Vehicle/Equipment Refueling		
1. Place a portable spill kit adjacent to the portable fuel tank to combat any potential spills or leaks. Ensure portable spill kit is present during refueling activities	Medium	1
Vehicle Maintenance		
Outdoor vehicle maintenance activities are not conducted at this facility.		
Vehicle/Equipment Washing		
Outdoor vehicle and equipment washing activities are not conducted at this facility.		
Material Storage		
EA has no BMP improvements for the facility under this activity.		
Aboveground Storage Tanks		
Outdoor aboveground storage tank activities are not conducted at this facility.		
Citizen Drop-Off Center		
Citizen drop-off activities are not conducted at this facility.		
Stockpiles		
Outdoor material stockpile activities are not conducted at this facility.		
Deicing Materials		
Deicing material storage activities are not conducted at this facility.		

Attachment A

**Good Housekeeping Plan Applicability Certification
Questionnaire**

GOOD HOUSEKEEPING PLAN (GHP)

APPLICABILITY CERTIFICATION

Facility Name: College of Southern Maryland Center for Transportation Trainin

Facility Address: 5825 Radio Station Road

La Plata, MD 20646

Date of Evaluation: 6/26/2025

To comply with Part IV.D.4.b of the County's Phase I Municipal Separate Storm Sewer System (MS4) Permit, the County must develop, implement, and maintain a Good Housekeeping Plan (GHP) for County-owned properties not required to be covered under Maryland's General Permit For Discharges from Stormwater Associated with Industrial Activities (General Permit 20-SW). The purpose of this certification is to evaluate and document if a specific County-owned facility is subject to the GHP requirements.

This evaluation shall be completed by an individual familiar with the operations of the property being assessed. One form must be completed for each facility or site for which you are seeking to certify GHP applicability. Additional guidance on completing this form is provided in the "Guidance Manual to GHP Applicability. This form shall be completed in its entirety.

This program applies to permanent/fixed locations only. Temporary work sites such as construction sites or roadways undergoing repairs or maintenance are excluded from this program.

This Certification must be reviewed and updated once every three (3) years, or within 90 days of substantial changes to a facility's operations which could reasonably contribute to stormwater pollution. Any newly constructed/acquired facility must be assessed within six (6) months of initiating operations at the facility.

A facility's GHP must be amended and reissued to the facility within 45 days of any changes to the facility's GHP Applicability Certification.

SECTION A – FACILITY OWNER INFORMATION (COUNTY/JURISDICTION)

1. **Jurisdiction Name:** Charles County
2. **Jurisdiction Address:** 200 Baltimore Street, La Plata, Maryland 20646
3. **GHP Program Contact Name:** Karen Wigger, Planner, Charles County Government
4. **GHP Program Contact Address:** 200 Baltimore Street, La Plata, Maryland 20646
5. **GHP Program Contact Information:** 301-645-0683 *(phone)*
WiggerK@charlescountymd.gov *(email)*

SECTION B – FACILITY OPERATOR INFORMATION (AGENCY/DEPARTMENT)

1. **Agency/Dept. Name:** College of Southern Maryland
2. **Agency/Dept. Address:** 8730 Mitchell Road
La Plata, MD 20646
3. **Agency/Dept. Contact Name:** Laura Dyson, Assistant Director, Facilities Management
4. **Agency/Dept. Contact Address:** 8730 Mitchell Road, PO Box 910
La Plata, MD 20646
5. **Agency/Dept. Contact Information:** 301-934-7734 *(phone)*
lldyson1@csmd.edu *(email)*

Good Housekeeping Plan Applicability Certification

SECTION C – FACILITY INFORMATION

1. **Facility Site Name:** College of Southern Maryland Center for Transportation Training
2. **Facility Site Address:** 5825 Radio Station Road
La Plata, MD 20646
3. **Facility Type:** Training Center
4. **Facility Contact Name:*** Laura Dyson, Assistant Director, Facilities Management
5. **Facility Contact Information:*** 301-934-7734 (phone)
lldyson1@csmd.edu (email)
6. **Facility Coordinates (decimal):** 38.55295074011971, -76.9506768839934
7. **Facility Size (acres):** Approximately 25 acres
8. **Environmental Justice Score:** ≤76 >76
9. **Facility in 100-yr. Floodplain:** Yes No
10. Is this facility covered under Maryland’s General Permit For Discharges from Stormwater Associated with Industrial Activities (General Permit 12-SWA / 20-SW)? Yes No
11. Has a “No Exposure” Certification been approved for this facility? Yes No

If you answer “Yes” to either question 10 or 11, complete Section D, and then stop. You do not have to complete Section E, as a GHP is only needed for a facility that is not covered under the 20-SW permit or an associated “No Exposure” certification.

* If different from the contact information provided in Section B.

SECTION D – PREPARER INFORMATION

Name: Allison Brown, Scientist I

Department/Company: EA Engineering, Science, and Technology, Inc., PBC

Date: 09/04/2025

Email Address: allisonbrown@eaest.com

Phone Number: 410-718-7450

Good Housekeeping Plan Applicability Certification

SECTION E – APPLICABILITY CHECKLIST

Are any of the following activities occurring at the facility, now or in the foreseeable future? Please check either "Yes" or "No" in the appropriate box. If you answer "Yes" to any of these questions, the facility will require a Good Housekeeping Plan, addressing all applicable activities.

Note: When a question asks if an activity is conducted outdoors, the intent is to determine if the activity has the potential to be exposed to stormwater or precipitation. Generally, activities conducted inside a building would not be considered "exposed". For the purposes of this document, a "building" shall be defined as a closed structure, in a fixed location, with a roof and walls on all sides. A "building" does not include storage sheds or shipping containers.

WASTE MANAGEMENT	NO	YES
1. Does this facility routinely generate industrial waste (i.e. waste produced by industrial or manufacturing activities), excluding minute amounts? <i>Examples include but are not limited to oil, solvents, chemicals, automotive fluids, pesticides, dirt, gravel, masonry, concrete, scrap metal, scrap lumber, etc.</i>	<input checked="" type="checkbox"/>	<input type="checkbox"/>
2. Are facility wastes stored in open-top roll-off dumpsters or other open-top containers, which are located outdoors?	<input checked="" type="checkbox"/>	<input type="checkbox"/>
3. Does this facility store scrap metal outdoors?	<input checked="" type="checkbox"/>	<input type="checkbox"/>
4. Is there a trash compactor in use at this facility?	<input checked="" type="checkbox"/>	<input type="checkbox"/>
5. Does this facility store Universal or Hazardous waste outdoors?	<input checked="" type="checkbox"/>	<input type="checkbox"/>
6. Is debris generated from street sweeping, storm drain cleaning, or other similar activities stored on-site, prior to disposal?	<input checked="" type="checkbox"/>	<input type="checkbox"/>
7. Is used cooking oil/grease, including grease disposal containers, stored at this facility, in an outdoor location?	<input checked="" type="checkbox"/>	<input type="checkbox"/>

VEHICLE AND EQUIPMENT STORAGE	NO	YES
1. Is heavy equipment or attachments (e.g. snow plow blades, breakers, etc.) routinely stored at this facility, in outdoor locations?	<input type="checkbox"/>	<input checked="" type="checkbox"/>
2. Are buses routinely stored at this facility, in outdoor locations?	<input type="checkbox"/>	<input checked="" type="checkbox"/>
3. Are garbage trucks, routinely stored at this facility, in outdoor locations?	<input checked="" type="checkbox"/>	<input type="checkbox"/>
4. Are fire engines, ladder trucks, police vehicles, ambulances, or other first responder vehicles, routinely stored at this facility, in outdoor locations?	<input checked="" type="checkbox"/>	<input type="checkbox"/>
5. Are fuel trucks, routinely stored at this facility, in outdoor locations?	<input checked="" type="checkbox"/>	<input type="checkbox"/>
6. Are vehicles, generally pick-up trucks, equipped with external fuel transfer tanks, routinely stored at this facility, in outdoor locations?	<input checked="" type="checkbox"/>	<input type="checkbox"/>
7. Are pick-up trucks/work trucks, with open beds that may contain potential stormwater pollutants, routinely stored at the facility, in outdoor locations?	<input checked="" type="checkbox"/>	<input type="checkbox"/>
8. Is portable, petroleum-powered equipment (e.g. pumps, portable light stands, portable generators, etc.) routinely stored at this facility, in outdoor locations?	<input checked="" type="checkbox"/>	<input type="checkbox"/>
9. Are damaged, wrecked, or scrap vehicles/equipment; or vehicles/equipment awaiting maintenance or transfer stored at this facility, in outdoor locations?	<input checked="" type="checkbox"/>	<input type="checkbox"/>

Good Housekeeping Plan Applicability Certification

VEHICLE/EQUIPMENT REFUELING	NO	YES
1. Are vehicle/equipment refueling activities performed on-site? <i>This would include vehicle refueling conducted outdoors or under a canopy but exclude refueling activities conducted entirely inside a building.</i>	<input type="checkbox"/>	<input checked="" type="checkbox"/>

VEHICLE MAINTENANCE	NO	YES
1. Are vehicle or equipment maintenance activities conducted at this facility, in an outdoor location, at any time?	<input checked="" type="checkbox"/>	<input type="checkbox"/>

VEHICLE/EQUIPMENT WASHING	NO	YES
1. Is vehicle/equipment washing conducted at this facility? <i>This could include pressure washing of vehicles or equipment to remove dirt or salt; heavy equipment wash downs, etc.</i> <i>This <u>excludes</u> the following activities:</i> a) Vehicle washing that is conducted in accordance with the terms and conditions of an existing State discharge permit; b) Vehicle washing that is conducted indoors with all washwater being either recycled or discharged to the sanitary sewer, in accordance with a wastewater discharge permit, as available; or c) Steam cleaning bays, located inside buildings, with all wastewater being discharged to the sanitary sewer, in accordance with a wastewater discharge permit, as available.	<input checked="" type="checkbox"/>	<input type="checkbox"/>

MATERIAL STORAGE	NO	YES
1. Do you store containers of oil-based products at this facility in outdoor locations? <i>This includes storage sheds, shipping containers, storage cabinets, or any other area that is not within a fixed building. This excludes oil-based products stored within underground or aboveground storage tanks.</i>	<input type="checkbox"/>	<input checked="" type="checkbox"/>
2. Do you store hazardous substances (e.g. paints, solvents, chemicals, cleaners, automotive fluids, pesticides, herbicides, etc.) at this facility in outdoor locations? <i>This includes storage sheds, shipping containers, storage cabinets, or any other area that is not within a fixed building. This excludes hazardous substances stored within underground or aboveground storage tanks.</i>	<input type="checkbox"/>	<input checked="" type="checkbox"/>
3. Do you store fertilizers at this facility in outdoor locations? <i>This includes storage sheds, shipping containers, storage cabinets, or any other area that is not within a fixed building.</i>	<input checked="" type="checkbox"/>	<input type="checkbox"/>
4. Do you store bags of erodible materials (excluding deicing materials) at this facility, in an outdoor location? <i>This includes but is not limited to soil, sand, cold patch asphalt, concrete, cement, grout, mulch, etc.</i>	<input checked="" type="checkbox"/>	<input type="checkbox"/>

Good Housekeeping Plan Applicability Certification

ABOVEGROUND STORAGE TANKS (ASTs)	NO	YES
1. Does this facility store oil-based product in an aboveground storage tank (AST) that is located outdoors? <i>(This excludes a generator set or "GenSet", which is a factory-supplied unit consisting of an emergency generator mounted on top of a fuel supply tank).</i>	<input checked="" type="checkbox"/>	<input type="checkbox"/>
2. Does this facility store chemicals or other hazardous substances in an AST that is located outdoors?	<input checked="" type="checkbox"/>	<input type="checkbox"/>
3. Does this facility store de-icing fluids in an AST that is located outdoors?	<input checked="" type="checkbox"/>	<input type="checkbox"/>

CITIZEN DROP-OFF CENTER	NO	YES
1. Does this facility provide an area where the public can dispose of used oil, waste antifreeze, or other waste oil-based products/hazardous substances?	<input checked="" type="checkbox"/>	<input type="checkbox"/>
2. Does this facility provide an area where the public can dispose of solid waste or recyclable materials?	<input checked="" type="checkbox"/>	<input type="checkbox"/>
3. Does this facility provide an area (collection center) where the public can drop off organic debris/waste for disposal?	<input checked="" type="checkbox"/>	<input type="checkbox"/>

STOCKPILES	NO	YES
1. Are stockpiles of erodible materials stored at this facility, in an outdoor location? <i>(This includes but is not limited to soil, sand, millings, slag, cinders, sawdust, landscaping bark, compost, etc.)</i>	<input checked="" type="checkbox"/>	<input type="checkbox"/>
2. Is cold mix asphalt stored in bulk at this facility, in an outdoor location?	<input checked="" type="checkbox"/>	<input type="checkbox"/>

DEICING MATERIALS	NO	YES
1. Is salt, abrasive-salt mix, or other aggregate deicing materials stored in bulk (e.g. loose form) at this facility?	<input checked="" type="checkbox"/>	<input type="checkbox"/>
2. Are stockpiles of bagged salt/deicing materials stored at this facility in outdoor locations?	<input checked="" type="checkbox"/>	<input type="checkbox"/>
3. Are vehicle-mounted salt spreaders/hoppers stored at this facility?	<input checked="" type="checkbox"/>	<input type="checkbox"/>
4. Are vehicles storing salt or salt-containing mixtures within open beds stored at this facility?	<input checked="" type="checkbox"/>	<input type="checkbox"/>

Is a GHP required for this facility: Yes No

If you answered "Yes" to any of the preceding questions, the facility would require a Good Housekeeping Plan, addressing all applicable activities.

If a GHP is required, which activities are to be included in the GHP?

Identify any activity in which a question above was answered "Yes".

- Waste Management
- Vehicle and Equipment Storage
- Vehicle/Equipment Refueling
- Vehicle Maintenance
- Vehicle/Equipment Washing
- Material Storage
- Aboveground Storage Tanks
- Citizen Drop-Off Center
- Stockpiles
- Deicing Materials

Attachment B

Best Management Practice Improvement Photograph Log

Attachment B Photograph Log

Photos taken during site visit performed on 6/26/2025.



Photograph No. 1

Portable fuel tank for refueling motorcycles inside of storage shed.

Appendix B

GHP-Applicable Facility Location Map

\\lovetongis\GIS\data\StateandLocal\Northeast\Maryland\16137\16137-24 GHP\16137-24 GHP\Effort.aprx jfoxworth

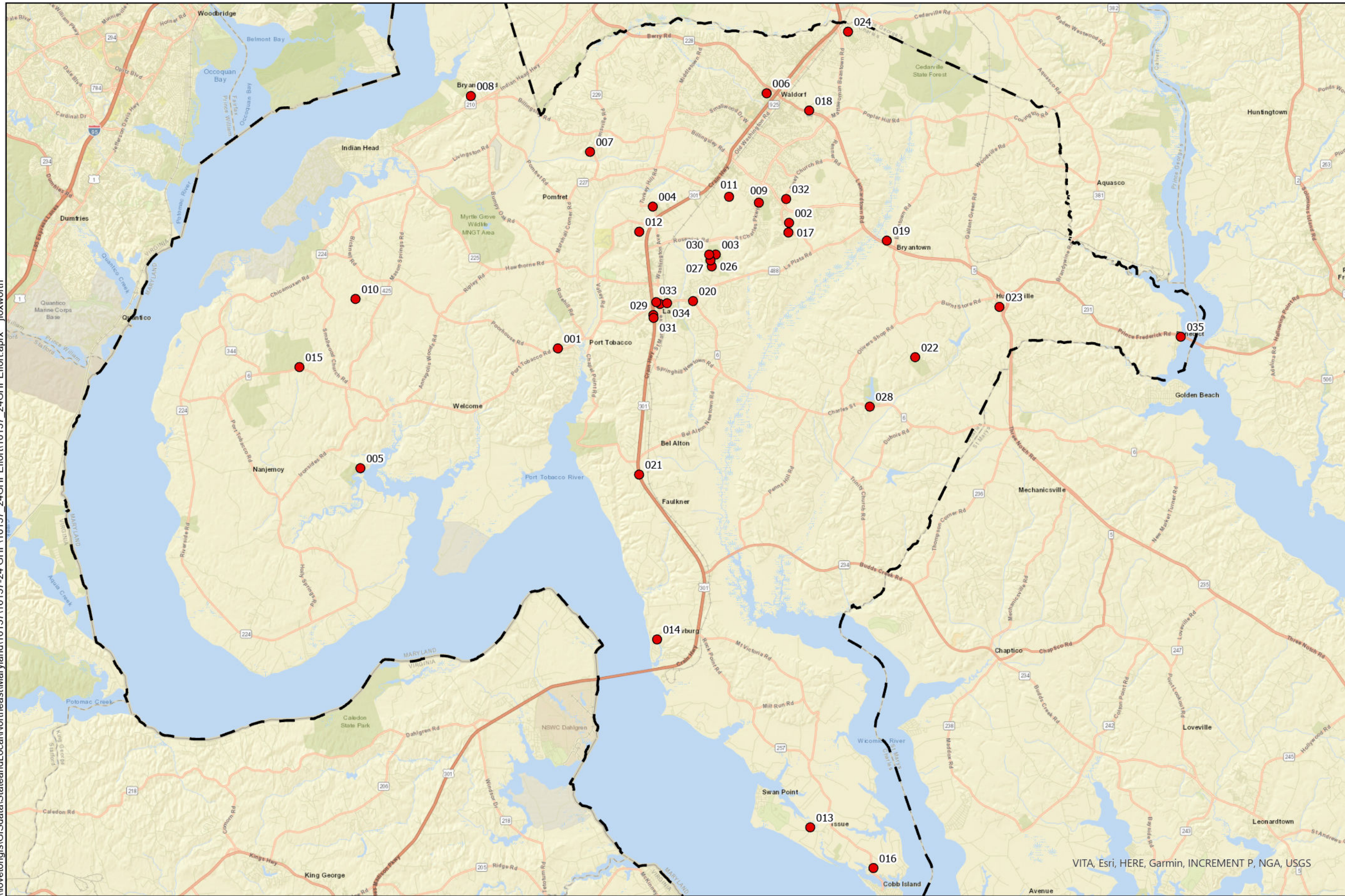

- Legend**
- GHP Applicable Facilities
 - Charles County Boundary

Map Date: 11/10/2025
 Source: ESRI Aerial 2016
 NOAA Navigation Channels



VITA, Esri, HERE, Garmin, INCREMENT P, NGA, USGS

Appendix B
Good Housekeeping Plan
Applicable Facilities
Charles County, Maryland

**Appendix B
Applicable Facilities Table**

FACILITY ID	PROPERTY ACCOUNT ID	FACILITY NAME	ADDRESS	RESPONSIBLE DEPARTMENT/ENTITY
001	901026267	PORT TOBACCO COMMUNITY CENTER	8190 PORT TOBACCO ROAD	DPW-FACILITIES-BLDGS & TRADES
002	908057923	PINEY CHURCH ROAD MULCH FACILITY	5370 PINEY CHURCH ROAD	DPW-FACILITIES-ER
003	901026704	LAUREL SPRINGS PARK	5940 RADIO STATION ROAD	RPT
004	906221076	TURKEY HILL PARK	9430 TURKEY HILL ROAD	RPT
005	903006565	FRIENDSHIP FARM PARK	4705 FRIENDSHIP LANDING ROAD	RPT
006	906302513	CAPITAL CLUBHOUSE	3033 WALDORF MARKET PLACE	GENERAL MANAGER FOR CAPITAL CLUBHOUSE
007	906053971	BENSVILLE PARK	6980 BENSVILLE ROAD	RPT
008	907040938	RUTH B SWANN RECYCLING CENTER	3100 RUTH B SWANN DRIVE	DPW-FACILITIES-ER
009	906066593	WHITE PLAINS PARK AND GOLF COURSE	1015 SAINT CHARLES PKWY	RPT
010	910008255	PISGAH RUN PARK, RECYCLING CENTER, AND SALT BARN	4825 PISGAH PARK PLACE	DPW-FACILITIES-ER-ROADS/RPT
011	906052193	SALT BARN AND PUMP STATION	4630 SALT BARN PLACE	DPW-FACILITIES-ROADS/DPW-UTILITIES OPS
012	906132502	MOUNT CARMEL WOODS SUBDIVISION	9325 MITCHELL ROAD	DPW-UTILITIES OPS
013	905014115	SWAN POINT WASTEWATER TREATMENT PLANT	12100 SWAN POINT ROAD	DPW-UTILITIES OPS
014	905027152	CLIFFTON ON THE POTOMAC WASTEWATER TREATMENT PLANT	9470 CLIFFTON DRIVE	DPW-UTILITIES OPS
015	903021157	SOUTHERN MARYLAND CRIMINAL JUSTICE ACADEMY	7682 ACADEMY PLACE	DPW-FACILITIES-BLDGS & TRADES
016	905037441	BREEZE FARM WASTEWATER TREATMENT PLANT, RECYCLING CENTER AND SALT BARN	15950 COBB ISLAND ROAD	DPW-UTILITIES OPS/DPW-FACILITIES-ER-ROADS

**Appendix B
Applicable Facilities Table**

FACILITY ID	PROPERTY ACCOUNT ID	FACILITY NAME	ADDRESS	RESPONSIBLE DEPARTMENT/ENTITY
017	908071217	CHARLES COUNTY STADIUM	11765 SAINT LINUS DRIVE	HEAD GROUNDSKEEPER FOR CHARLES COUNTY STADIUM
018	906112668	SHERIFF'S OFFICE DISTRICT 3	3670 LEONARDTOWN ROAD	DPW-FACILITIES-BLDGS & TRADES
019	908019193	BRYANTOWN SPORTS COMPLEX	5665 BRANDYWINE ROAD	RPT
020	901005693	CLARK CENTER	1210 CHARLES STREET	DPW-FACILITIES-BLDGS & TRADES
021	904009908	BEL ALTON HIGH SCHOOL MULTI-SERVICE CENTER	9505 CRAIN HIGHWAY	DPW-FACILITIES-BLDGS & TRADES/DPW-UTILITIES OPS
022	908012814	OAK RIDGE PARK	13675 OAKS ROAD	RPT
023	909009833	HUGHESVILLE PARK	15120 HUGHESVILLE SCHOOL ROAD	RPT
024	908050708	PINEFIELD OIL AND ANTIFREEZE DROP-OFF FACILITY	12705 COUNTRY LANE	DPW-FACILITIES-ER
025	901026151	CHARLES COUNTY CIRCUIT COURT	200 CHARLES STREET	DPW-FACILITIES-BLDGS & TRADES
026	901072099	MUDD'S WAY MULCH FACILITY FOR PARKS AND ROADS	MUDD'S WAY	RPT
027	901026712	SHERIFF'S OFFICE ANNEX AND EMERGENCY SERVICES	10435 AUDIE LANE	DPW-FACILITIES-BLDGS & TRADES
028	908032866	GILBERT RUN PARK AND RECYCLING CENTER	13140 CHARLES STREET	DPW-FACILITIES-ER/RPT
029	901003364	SHERIFF'S OFFICE DISTRICT 1 SUBSTATION AND ANNEX	6855 CRAIN HIGHWAY	DPW-FACILITIES-BLDGS & TRADES
030	901072102	COLLEGE OF SOUTHERN MARYLAND CENTER FOR TRANSPORTATION	5825 RADIO STATION ROAD	ASSISTANT DIRECTOR OF FACILITIES, MANAGEMENT, OPERATIONS & PLANNING
031	901002465	SHERIFF'S OFFICE HEADQUARTERS AND DETENTION CENTER	6915 CRAIN HIGHWAY	DPW-FACILITIES-BLDGS & TRADES
032	908031983	STETHEM PARK	4250 PINEY CHURCH ROAD	RPT

Appendix B
Applicable Facilities Table

FACILITY ID	PROPERTY ACCOUNT ID	FACILITY NAME	ADDRESS	RESPONSIBLE DEPARTMENT/ENTITY
033	901026216	CHARLES COUNTY GOVERNMENT BUILDING	200 BALTIMORE STREET	DPW-FACILITIES-BLDGS & TRADES
034	901026283	SHERIFF'S OFFICE FORENSIC SCIENCE UNIT	100 KENT AVENUE	DPW-FACILITIES-BLDGS & TRADES
035	909005277	BENEDICT PARK	SOUTH SI ROUTE 231	RPT

Acronyms:

BLDG = Building

DPW = Department of Public Works

ER = Environmental Resources

RPT = Recreation, Parks, & Tourism

Utilities Ops = Utilities Operations

Appendix C

GHP Site Inspection Checklist

GOOD HOUSEKEEPING PLAN (GHP) SITE INSPECTION CHECKLIST

Facility Name: _____	Inspection Date: _____
Inspector Name: _____	Inspector Signature: _____

- The following form represents the inspection checklist conducted and maintained electronically within the OpenGov Enterprise Asset Management System.
- The intent of this inspection is to ensure that the site is being properly maintained and that there are no visible signs of pollutants entering the stormwater system.
- **A shaded status box designates an item in a non-compliant status. Please provide an explanation for all non-compliant items and subsequently document all corrective actions performed.**
- Retain the completed checklists for five (5) years.

Item	Status			CORRECTIVE ACTIONS/COMMENTS <i>Items which cannot be corrected immediately must be reported to the GHP/NPDES Program Manager</i>
	Yes	No	N/A	
GENERAL HOUSEKEEPING				
1. Are exterior areas of the facility free of accumulated trash, debris, and unneeded materials?				
2. Are stormwater drains and inlets free from debris, sediment, and evidence of spills/releases?				
3. Is the facility free from signs of erosion?				
4. Are paved surfaces free of accumulated sediment?				
5. Is spill response equipment available in maintenance areas, fueling areas, hazardous material storage areas, and/or other required areas?				
6. Are spill kits and absorbent materials clearly labeled and accessible (i.e. items are not piled on top of or in front of spill kits)?				
7. Are spill kits secured from being stolen or misused?				

GOOD HOUSEKEEPING PLAN (GHP) SITE INSPECTION CHECKLIST

Item	Status			CORRECTIVE ACTIONS/COMMENTS <i>Items which cannot be corrected immediately must be reported to the GHP/NPDES Program Manager</i>
	Yes	No	N/A	
8. Is there a labeled container present for the disposal of used spill cleanup material?				
9. Does spill response equipment (i.e. spill kits, absorbent materials) need to be replenished?				
WASTE MANAGEMENT				
10. Are areas around solid waste containers/roll-offs/compactors free of excessive trash accumulation or overflowing containers?				
11. Are areas around solid waste containers/roll-offs/compactors free of visible evidence (i.e. leaks, staining) of ongoing stormwater pollution?				
12. Are scrap metal containers in good order and free from evidence of leaking oil/grease?				
13. For dumpsters, roll-offs, and other waste receptacles, where leaks are observed, have appropriate controls (e.g. containment, spill response, etc.) been enacted?				
14. Are the lids (if present) to solid waste containers closed?				
15. Is street sweeping/vactor waste being managed appropriately (i.e. no evidence of material migration)?				
16. Is waste cooking grease managed appropriately (i.e. no evidence of spilled material or excessive staining)?				
VEHICLE & EQUIPMENT STORAGE				
17. Are stored vehicles/equipment free from leaks?				
18. If leaks are present, are they being managed appropriately (drip pan or other methods in place to capture released liquids)?				

GOOD HOUSEKEEPING PLAN (GHP) SITE INSPECTION CHECKLIST

Item	Status			CORRECTIVE ACTIONS/COMMENTS <i>Items which cannot be corrected immediately must be reported to the GHP/NPDES Program Manager</i>
	Yes	No	N/A	
19. Are storage areas free of visible evidence of chronic leaks/spills (i.e. significant staining)?				
VEHICLE & EQUIPMENT REFUELING				
20. Are the areas around refueling areas free from evidence of spills or leaks?				
21. Are refueling areas free of used absorbent material that has not been swept/cleaned up?				
22. Do fuel dispensers and hoses appear to be in good working order and well-maintained?				
VEHICLE MAINTENANCE				
23. Is there any indication that vehicle maintenance activities are being conducted outdoors?				
24. Is there any indication that vehicle maintenance activities are contributing to stormwater pollution?				
VEHICLE & EQUIPMENT WASHING				
25. If performed on-site, does all vehicle/equipment washing occur indoors?				
26. Is wash water collected and disposed of properly?				
27. Is there any indication that vehicle/equipment wash water is being released to stormwater conveyances or pervious areas?				
MATERIAL STORAGE				
28. Are all outdoor storage areas free from visible signs of leaks or spilled material?				

GOOD HOUSEKEEPING PLAN (GHP) SITE INSPECTION CHECKLIST

Item	Status			CORRECTIVE ACTIONS/COMMENTS <i>Items which cannot be corrected immediately must be reported to the GHP/NPDES Program Manager</i>
	Yes	No	N/A	
29. Are material storage containers in good condition?				
30. Are drums, totes, and other containers (that are <u>not</u> empty) stored off the ground and covered, or stored indoors?				
31. Are liquid-containing drums/totes located outdoors provided with secondary containment?				
32. Are containers that are located outdoors equipped with closed lids except when material transfers are occurring?				
33. Are materials, which could impact stormwater, stored away from heavy traffic areas, or protected from vehicle collisions?				
34. Are chemical storage containers properly labeled?				
35. If empty drums are stored outside, are all openings equipped with caps to prevent water intrusion?				
ABOVEGROUND STORAGE TANKS				
36. Are all storage tanks, and surrounding areas free from visible signs of leaks or spilled material?				
37. Do storage tanks appear to be in good working order (e.g. free of obvious signs of damage or malfunctioning equipment)?				
38. Are remote fills associated with tanks free of liquid and debris?				
RESIDENT DROP-OFF CENTERS				
39. Are waste collection areas clearly identified?				

GOOD HOUSEKEEPING PLAN (GHP) SITE INSPECTION CHECKLIST

Item	Status			CORRECTIVE ACTIONS/COMMENTS <i>Items which cannot be corrected immediately must be reported to the GHP/NPDES Program Manager</i>
	Yes	No	N/A	
40. Are used oil/antifreeze collection tanks, containment structures, and surrounding areas free from visible signs of leaks or spilled material?				
41. Do used oil/antifreeze collection tanks appear to be in good working order (e.g. free of obvious signs of damage or malfunctioning equipment)?				
42. Are empty used oil/antifreeze containers being collected and disposed of in the trash?				
43. Are areas around waste/recyclables containers free of excessive trash accumulation or overflowing containers?				
44. Are areas around waste/recyclables containers free of visible evidence (i.e. leaks, staining) of ongoing stormwater pollution?				
45. Are organic debris collection areas free of visible evidence of ongoing stormwater pollution (e.g. leaves and debris in stormwater conveyances)?				
STOCKPILES				
46. Are material piles, including salt, soil, sand, and millings isolated (i.e. covered, bermed, etc.) to prevent stormwater run-on and run-off?				
47. Are areas surrounding material piles (e.g. salt, soil, sand, millings, etc.) free of tracked or migrated material?				
DEICING MATERIALS				
48. Are all deicing materials stored indoors or undercover?				
49. Are salt storage structures in good condition (e.g. no evidence of material escaping or stormwater infiltration)?				

GOOD HOUSEKEEPING PLAN (GHP) SITE INSPECTION CHECKLIST

Item	Status			CORRECTIVE ACTIONS/COMMENTS <i>Items which cannot be corrected immediately must be reported to the GHP/NPDES Program Manager</i>
	Yes	No	N/A	
50. Is the salt loading area clean?	<input type="checkbox"/>	<input checked="" type="checkbox"/>	<input type="checkbox"/>	
51. If deicing materials are tarped, is the tarp secure and covering the entire pile?	<input type="checkbox"/>	<input checked="" type="checkbox"/>	<input type="checkbox"/>	
52. Are bags of salt stored indoors, or off the ground and covered?	<input type="checkbox"/>	<input checked="" type="checkbox"/>	<input type="checkbox"/>	

ADDITIONAL COMMENTS:

Appendix D1

GHP Stormwater Conveyance System Inspection Checklist

GOOD HOUSEKEEPING PLAN (GHP) STORMWATER CONVEYANCE SYSTEM INSPECTION CHECKLIST

Facility Name: _____	Inspection Date: _____
Inspector Name: _____	Inspector Signature: _____

- The following form represents the inspection checklist conducted and maintained electronically within the OpenGov Enterprise Asset Management System.
- The intent of this inspection is to ensure the free flow of stormwater within on-site conveyance systems and prevent damage/flooding.
- **If maintenance is needed, please provide an explanation, and document all corrective actions performed.**
- **Inspections shall include visually accessible infrastructure only; at no time shall inspection personnel enter a confined space.**
- Retain the completed checklists for five (5) years.

Item	Item Checked (Y/N/NA)	Maintenance Needed (Y/N)	CORRECTIVE ACTIONS/COMMENTS <i>Items which cannot be corrected immediately must be reported to the GHP/NPDES Program Manager</i>
CATCH BASINS / INLETS			
1. Look for debris and sediment blocking catch basin grates. If found, remove.			
2. Look for damage or cracks to the frame, grate, basin walls or bottom. If found, schedule repairs or replacement.			
3. Look for sediment and debris in the catch basin sump. If sediment fills 60% of the sump or comes within 6" of a pipe it should be scheduled for cleaning.			
4. If any type of filtering device is present, verify that the filter is not clogged, torn, or damaged; clean if clogged, replace if damaged.			
PIPES / CULVERTS			
5. Look for evidence of clogged piping (e.g. visual obstructions, standing water within manholes/inlets structures, etc.). If found, remove or schedule cleaning.			
6. Verify vegetation growth, if present, does not impede water flow. If it does, mow, cut back, or remove.			

GOOD HOUSEKEEPING PLAN (GHP)

STORMWATER CONVEYANCE SYSTEM INSPECTION CHECKLIST

Item	Item Checked (Y/N/NA)	Maintenance Needed (Y/N)	CORRECTIVE ACTIONS/COMMENTS <i>Items which cannot be corrected immediately must be reported to the GHP/NPDES Program Manager</i>
7. Inspect for damaged piping, inlets, outlets, headwalls, wingwalls, or excessive erosion. If found, make or schedule repairs.			
DITCHES / TRAPEZOIDAL SWALES			
8. Check for erosion, slumping, or undercutting. If found, make or schedule repairs.			
9. Look for trash and sediment accumulation. Remove all trash and remove sediment if it will impede water flow or clog downstream structures.			
10. Verify vegetation growth does not impede water flow. If it does, mow, cut back, or remove. Remove any trees or shrubs growing within the ditch.			
11. Check the integrity of check dams, filter socks, or other flow dissipation/filtering devices within the ditch or swale. Perform or schedule service if they are clogged, damaged, or deteriorated.			
12. Check inlets and outlets for debris accumulation, damage, or erosion. If found, make or schedule repairs.			

ADDITIONAL COMMENTS:

Appendix D2

Stormwater Conveyance Inspection Guidance Document

GUIDANCE DOCUMENT

GOOD HOUSEKEEPING PLAN - STORMWATER CONVEYANCE INSPECTIONS

INTRODUCTION

Maintaining catch basins, stormwater inlets, and other stormwater conveyance structures on a regular basis will remove pollutants, prevent backups, and ensure the system functions as intended to avoid flooding.

Each GHP-covered facility is required to conduct routine stormwater conveyance system inspections to ensure the free flow of stormwater within the conveyance system(s). The GHP includes a “*GHP Stormwater Conveyance System Inspection Checklist*”, to be used when completing the required inspections. This document provides additional background and guidance to aid facility personnel in completing the inspections.

CATCH BASINS / INLETS

Catch basins and inlets are all points for stormwater to enter storm drain systems. These structures are typically part of a larger conveyance system with many interconnected components where the impairment of one component can compromise the functionality of the larger system. Inlets and catch basins are subject to functional impairment by a variety of conditions, including:

- Structural damage including from vehicles and plows
- Cracks/joint separation at piping (inlet and outlet) connections
- Leaking due to cracks and joint separation
- Missing or damaged grates and grate frames
- Corrosion
- Blockage caused by debris, sediment, vegetation, or other objects

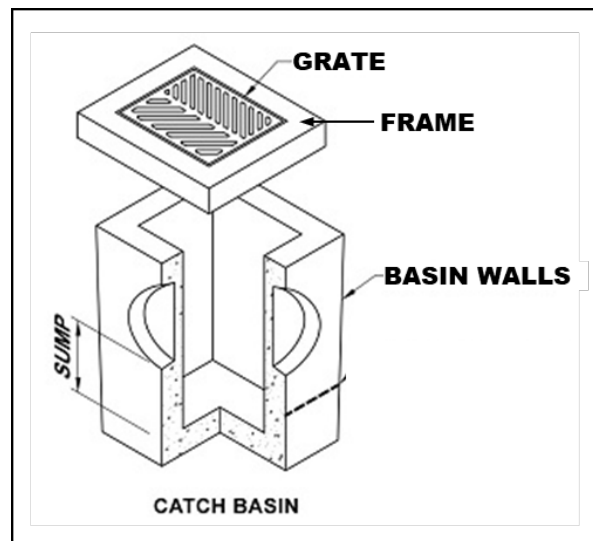

Figure 1 – Catch Basin Diagram

The following photos provide additional information related to the various inspection items, including examples of typical issues that may be encountered. The photo numbers correspond to the inspection checklist item number.

Guidance Document – Good Housekeeping Plan Stormwater Conveyance Inspections

Inspection Item #1 ¹



Debris and sediment blocking inlet/catch basin grate.

Inspection Item #2 ²



Damaged Grate

Inspection Item #2 ³



Damaged Frame

Inspection Item #2 ⁵



Failing asphalt surrounding the inlet

Inspection Item #2 ⁴



Failing brick walls with a stormwater inlet.

¹ Grand Valley State University - <https://www.gvsu.edu/groundswell/clogged-storm-drains-71.htm>

² Georgia Department of Transportation – Stormwater System Inspection and Maintenance Manual, March 2020

³ <https://catchbasinauthority.ca/catch-basin-101/>

⁴ <https://www.fixasphalt.com/catch-basin-repairs>

⁵ <https://ccpia.org/catch-basin-and-manhole-inspections/>

Inspection Item #3⁶



Sediment and debris inside stormwater inlet

Inspection Item #3



Remove sediment from a catch basin if it fills 60% of the sump or comes within 6" of a pipe.

Inspection Item #4⁷



Example of inlet filter. Replace when filled or damaged.

Inspection Item #4⁸



Example of an inlet filter sock, replace if damaged.

PIPES AND CULVERTS

Pipe systems are designed to convey stormwater runoff safely and effectively from inlets to various discharge points and outfalls. A culvert is a structure that channels water under an obstacle such as a roadway or railroad. These structures are subject to functional impairment by a variety of conditions, including:

- Blockage or obstruction due to build up of vegetation, debris, sediment, or other objects
- Cracks and/or joint separation
- Collapsed pipe
- Corrosion
- Root intrusion
- Lack of stabilization

⁶ <https://www.fixasphalt.com/catch-basin-repairs>

⁷ <https://store.interstateproducts.com/products/Ultra-Drain-Guards/Ultra-Drain-Guard-Adjustable-Frame-Model>

⁸ <https://www.newpig.com/pig-sediment-filter-sock/p/FLT787>

Inspection Item #5⁹



A pipe filled with sediment, inhibiting flow.

Inspection Item #5¹⁰



Standing water around an inlet may indicate a blockage.

Inspection Item #6¹¹



Pipe conveyance filled with vegetation.

Inspection Item #7¹²

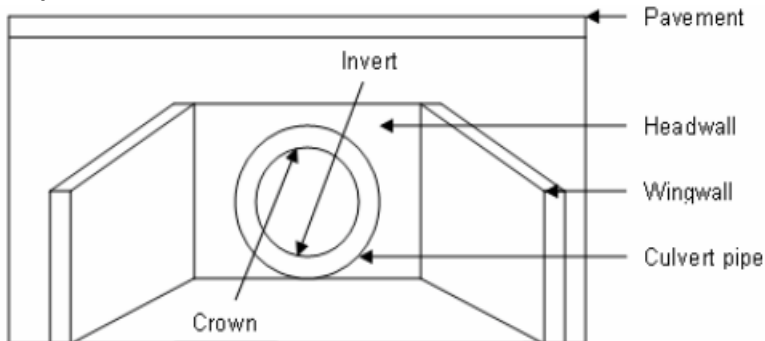

Diagram depicting various components of a culvert.

⁹ Georgia Department of Transportation – Stormwater System Inspection and Maintenance Manual, March 2020

¹⁰ <https://www3.epa.gov/region9/water/npdes/stormwater-feature.html>

¹¹ Georgia Department of Transportation – Stormwater System Inspection and Maintenance Manual, March 2020

¹² https://www.researchgate.net/figure/Components-of-a-Culvert_fig34_228685906

Inspection Item #7¹³



A crack in the culvert headwall.

Inspection Item #7¹⁴



Evidence of erosion around a culvert.

DITCHES AND SWALES

Ditches and swales serve similar functions. Both are used to convey stormwater. However, there are slight differences. A ditch is a narrow channel typically found along roads and at the edges of parking lots/driveways. A swale is like a ditch, but it is broad and shallow, and usually covered or lined with turfgrass or stone. Issues associated with these structures, which could impede their function include:

- Blockage or obstruction due to vegetation, debris, sediment, or other objects
- Erosion
- Rapidly moving water
- Lack of adequate vegetative cover for grass-lined channels

Inspection Item #8¹⁵



Erosion and slumping within a drainage ditch.

Inspection Item #8¹⁶



Slumping within a drainage swale.

¹³ <https://www.sbt-durabi.org/articles/xml/ARN0/>

¹⁴ https://lufkindailynews.com/news/local/culverts-crumbling-in-precinct-1/article_a9fed902-4379-5248-ab11-7471e2974298.html

¹⁵ <https://graniteseed.com/blog/how-to-stop-a-ditch-from-eroding/>

¹⁶ <https://www.mnwcd.org/erosion-control>

Guidance Document – Good Housekeeping Plan Stormwater Conveyance Inspections

Inspection Item #9 ¹⁷



Litter and debris within a ditch.

Inspection Item #9 ¹⁸



Litter and debris within a swale.

Inspection Item #10 ¹⁹



Cracks and joint separation in concrete channels, removal of vegetation may prevent future damage.

Inspection Item #11 ²⁰



Rock check dam across a channel.

Inspection Item #11 ²¹



Filter sock check dams across a grass swale.

¹⁷ <https://craven.ces.ncsu.edu/2023/02/for-those-who-love-to-litter/>

¹⁸ <https://www.cityoftulsa.org/government/departments/public-works/stormwater-quality/adopt-a-stream/>

¹⁹ Georgia Department of Transportation – Stormwater System Inspection and Maintenance Manual, March 2020

²⁰ EPA Stormwater Best Management Practice, Check Dams, December 2021

²¹ EPA Stormwater Best Management Practice, Check Dams, December 2021

Inspection Item #12 ²²



Inlet to a rock-lined swale.

Inspection Item #12 ²³



Sediment accumulation at swale inlet.

END OF DOCUMENT

²² <https://www.stormwater.com/erosion-control/vegetation-management/article/13016118/inlet-protection-during-constructionand-after>

²³ <https://www.stormwater.com/erosion-control/vegetation-management/article/13016118/inlet-protection-during-constructionand-after>

Appendix E

General Spill Response Procedures

SPILL RESPONSE AND NOTIFICATION PROCEDURES

A. Discovery of a Spill

1. Upon discovery of a spill, facility personnel should immediately assess the situation and determine if the spill is considered a “Minor” or “Major” spill. For a spill to be considered “Minor” all the following conditions must be satisfied:
 - ❖ The type of material spilled is known;
 - ❖ The spill is confined to the immediate work area;
 - ❖ The spill has not reached storm drains, sanitary sewer systems, open water, or surrounding soils;
 - ❖ The spill can be safely managed;
 - ❖ The employee can contain and clean up the spill with the PPE that is normally used in the work area;
 - ❖ The spill does not pose a serious threat of fire or an explosion; and
 - ❖ The spill does not pose conditions that are immediately dangerous to life or health.
2. If all the above conditions are met, the spill is considered “Minor”. Refer to **Section B** of this document for appropriate response actions.
3. If all the above conditions are not met, then the spill is considered “Major”. Refer to **Section C** of this document for appropriate response actions.
4. If a spill involves flammable liquids, ignitable vapors may be present - precautions must be taken to prevent ignition. Do not turn on or off equipment since sparks may be generated. Additionally, avoid the movement of equipment that could create static electricity. Larger spills of flammable liquids could pose a fire threat and would be considered a “Major” spill. Refer to **Section C** for appropriate actions.

B. Response to a “Minor” Spill

1. Identify the source of the spill and the direction in which the spill is heading.
2. Attempt to stop the spill at the source. Where applicable, the source of the spill shall be taken out of service until repairs can be made. If the spill is related to a fuel dispensing system, activate the Emergency Shut-Off (ESO) switch to prevent additional fuel disbursements.
3. If material is released outside a containment area, it is crucial that the material be contained as quickly as possible. Following proper safety procedures, use absorbent materials or diking to contain the spill. Prevent the spill from reaching storm drains, sanitary sewers, or open water. If a spill is flowing toward a drain, install temporary diking around the drain, block off the drain with a drain cover, or place absorbent material around the drain to prevent a discharge.
4. Once the spill has been stopped and contained, estimate the quantity of the spill. Consult applicable Safety Data Sheet (SDS) for material compatibility and environmental precautions. Note and follow recommendations regarding special precautions, spill response equipment, methods, or precautions. All cleanup work shall be conducted in accordance with existing safety protocols and SDS recommendations. Contact the facility Superintendent/Supervisor, or designee, for assistance if needed.

5. Recover or clean up the spilled material as much as possible. Material that cannot be reused must be discarded in accordance with state and federal regulations. Liquids absorbed by porous materials (e.g., wood, gravel, significant quantities of absorbent material, etc.) shall be placed into US DOT-approved 30-gallon or 55-gallon steel drums. Following cleanup, the container shall be secured and appropriately labeled to identify the contents and the date of the spill/cleanup. Containers shall be stored indoors and provided with secondary containment until transported off-site for disposal.
6. For spills that do not involve flammable liquids or other potential hazardous wastes, small quantities of used absorbent materials may be double bagged and disposed of along with municipal trash as long as all liquids have been absorbed (no free liquid may be present).
7. If the spilled material is a flammable liquid, corrosive liquid (pH ≤ 2 or ≥ 12.5), or other potential hazardous waste, all recovered product, impacted material, and used absorbent must be placed into a US DOT-approved containers/drums. Following cleanup, the container(s) shall be secured and appropriately labeled to identify the contents and the date of the spill/cleanup. Containers shall be stored indoors and provided with secondary containment until transported off-site for disposal. The facility Superintendent/ Supervisor, or designee shall be notified that a potential hazardous waste was released and that a waste characterization may be needed to facilitate proper disposal.
8. Surfaces that are contaminated by the spill shall be cleaned utilizing dry absorbent material. Tools and equipment that have been used in the cleanup must be decontaminated immediately after use. Decontamination water (if used) must be minimized, containerized, and disposed of properly.
9. If waste requires disposal, notify the facility Superintendent/Supervisor, or designee who will arrange for the proper characterization and disposal of any waste material. Representative sampling and analysis may be necessary to properly characterize the waste. The waste must be transported and disposed of in compliance with all applicable laws and regulations. Waste manifests, trip tickets, or bills of lading (if required) for waste disposal shall be kept on file.
10. Facility personnel shall restock/replace spill response equipment and absorbent materials used during the clean-up efforts.
11. The facility Superintendent/Supervisor, designee, or other appropriate County personnel shall be notified of the spill in accordance with **Section D** of this document.

C. Response to “Major” Spill

A “Major” spill is any discharge that does not meet the definition of a “Minor” spill. Any employee or contractor observing, being involved with, or recognizing a potential or actual spill of oil or other hazardous material, other than a “Minor” spill is responsible for performing the following actions:

1. If there is no danger to human health, attempt to stop and contain the spill at the source. If the spilled material is unknown, if PPE other than that which is typically used in your work area, is necessary to approach the spill area, or if assistance is required to stop the spill, do not attempt to contain the spill. If the spill is related to a fuel dispensing system, activate the Emergency Shut-Off (ESO) switch.

2. Most County employees lack the appropriate training to respond to “Major” spills. If the spill is of an unknown substance, is of a quantity that cannot be safely managed, or poses other risks beyond the training level of the employee, the employee should not attempt to contain or clean up the spill.
3. Evacuate individuals from the area and keep personnel away from the impacted area.
4. Immediately notify the facility Superintendent/Supervisor, or designee of the incident. The notified individual will determine the need for further evacuations and contact emergency response personnel (911), as necessary. *If a situation represents an immediate and grave danger to personnel, the public, structures, or other infrastructure, the individual discovering the incident may call 911 directly without first notifying facility management.*
5. The facility Superintendent/Supervisor or designee will determine if assistance from emergency response contractors is required to clean up the incident and will coordinate such spill response efforts with spill response contractors and other County agencies and first responders.
6. Facility personnel will provide assistance to emergency responders, as appropriate.

D. Reporting a Spill (Internal Notifications)

1. Once a spill is contained and cleanup operations have been initiated, the individual discovering the spill shall notify the appropriate County representatives and provide the following information:
 - a) Identify the location, date, and time of the incident;
 - b) Identify the type of material spilled or discharged;
 - c) Estimate the quantity spilled and the rate of the spill;
 - d) Identify the cause of the spill or discharge;
 - e) Identify impacted media or infrastructure (soil, storm drains, open water bodies, etc.);
 - f) Determine the extent of injuries involved; and
 - g) Provide response measures implemented by the facility personnel.

E. Reporting a Spill (Regulatory Notifications)

State of Maryland Reporting Requirements ([COMAR 26.10.01.05](#))

1. Upon discovery of a spill, the Responsible Person shall notify the MDE Emergency Response Division **within two (2) hours** by calling 866-633-4686. The caller shall be prepared to provide the following information:
 - a) The time and date of the spill;
 - b) The location and cause of the spill;
 - c) The mode of transportation or type of facility involved;
 - d) Type and quantity of oil spilled;
 - e) Details regarding any assistance required;
 - f) The name, address, and telephone number of the person making the report; and
 - g) Any other pertinent information requested by the Department.

2. MDE will provide further guidance on additional responsibilities.
3. Within **ten (10) working days** of the completed removal and clean-up activities, the Responsible Person shall prepare a report using either County letterhead detailing the incident. The report shall contain the following:
 - a) Date, time, and place of the spill;
 - b) The amount and type of oil or hazardous substance spilled;
 - c) A complete description of circumstances that contributed to the spill;
 - d) A complete description of the containment and removal operations performed, including disposal sites to which oil refuse was transported;
 - e) Procedures, methods, and precautions instituted to prevent the recurrence of an oil spill from the facility involved;
 - f) Any other information considered necessary or required by the MDE for a complete description of the incident; and
 - g) A certification that the information provided is true and correct to the knowledge of the person signing the report.
4. The completed report shall be submitted to mdeerd.mema@maryland.gov or faxed to 410-537-3932.
5. A digital copy of the completed report and any accompanying documentation shall be retained

Federal Reporting Requirements - National Response Center ([40 CFR 110](#))

1. If any of the following criteria are met the Responsible Person shall notify the National Response Center (NRC) **within two (2) hours** of the spill discovery by calling 800-424-8802 or 202-426-2675.
 - ❖ The spill has caused a film, sheen, or discoloration of the surface water or shorelines;
 - ❖ The material spilled will violate applicable water quality standards (surface water or groundwater); or
 - ❖ The spill has caused a sludge or emulsion to be deposited beneath the surface of the water or on the shoreline.
2. At a minimum, the following information shall be provided to the NRC:
 - a) Name, organization, and telephone number of reporting party;
 - b) Name and address of the responsible party;
 - c) Date, time, and location of the incident;
 - d) Source and cause of the discharge;
 - e) Type of material(s) discharged;
 - f) Quantity of materials discharged;
 - g) Danger or threat posed by discharge;
 - h) Number and types of injuries (if any);
 - i) Weather conditions at the incident location; and
 - j) Other information to help emergency personnel respond to the incident.

3. If unable to report to the NRC, reports can be made to the EPA Regional Office at 800-438-2474 or the U.S. Coast Guard (USCG) at 202-372-1001. The NRC, EPA, or USCG will provide further guidance.
4. A digital record of the NRC notification and any accompanying documentation shall be retained on-site.

Federal Reporting Requirements - EPA Regional Administrator ([40 CFR 112.4](#))

1. If the facility where the spill occurred is regulated under 40 CFR 112 and is required to have a Spill Prevention, Control, and Countermeasures (SPCC) Plan, the Responsible Person shall report the spill to the EPA Region III Administrator when any of the following criteria are met:
 - ❖ More than 1,000 gallons of oil is discharged to navigable waters or adjoining shorelines in a single incident; or
 - ❖ More than 42 gallons of oil is discharged to navigable waters or adjoining shorelines in each of two incidents occurring within any twelve-month period.
2. The report shall be made in writing **within 60 days** of the spill and shall contain:
 - a) Name and location of the facility;
 - b) Owner/operator name;
 - c) Maximum storage/handling capacity of the facility and normal daily throughput;
 - d) Corrective actions and countermeasures taken;
 - e) Adequate description of the facility including maps, and flow diagrams;
 - f) Cause of the discharge to navigable waters, including a failure analysis;
 - g) Additional preventative measures taken or planned to minimize discharge recurrence; and
 - h) Other information required by the EPA Regional III Administrator.
3. The report shall be submitted to the EPA Regional Administrator at the following address:

EPA Regional Administrator
US EPA Region 3
1650 Arch Street (3RA00)
Philadelphia, PA 19103-2029

4. A copy of the report shall be retained at the facility or with the facility's SPCC Plan.